

## COMANT TRANSPONDER ANTENNA - REMOVAL/INSTALLATION

### 1. General

- A. This section gives the removal and installation procedures for the Comant Transponder antenna. For a general overview of the GTX-33/GTX-33ES Transponder System refer to Garmin GTX-33/GTX-33ES Transponder System - Description and Operation.

### 2. Tools and Equipment

- A. Tools and Equipment
- None.
- B. Special Consumables
- None.
- C. Reference Material
- Chapter 20, Electrical Bonding - Maintenance Practices
  - Chapter 20, Fuel, Weather and High-Temperature Sealing - Maintenance Practices
  - Garmin GTX-33/GTX-33ES Transponder System - Description and Operation
  - Garmin GTX-33/GTX-33ES Transponder System - Adjustment/Test.

### 3. Setup

- A. Prepare the Airplane
- (1) Make sure that the BATTERY switch is in the OFF position.
  - (2) Make sure that the AVIONICS switches are in the OFF position.
  - (3) Disconnect external electrical power from the airplane.
  - (4) Disengage the applicable circuit breaker given in Table 401.

**Table 401. Circuit Breakers**

Circuit Breaker Name	Circuit Breaker Location
XPDR 1	Avionics Circuit Breaker Panel
XPDR 2 (Optional with second transponder installation)	Avionics Circuit Breaker Panel

### 4. Comant Transponder Antenna Removal (Without Cargo Pod)

**NOTE:** The airplane can have one or two transponder antennas. The removal and installation procedures for the transponder antennas are typical. The transponder antennas are found on the bottom of the airplane at FS 154.30, LBL 11.53 for transponder antenna 1, and FS 154.30, RBL 11.53 for transponder antenna 2.

- A. Remove the Transponder Antenna (Refer to Figure 401).
- (1) Remove the screws from the transponder antenna.
  - (2) Carefully pull the transponder antenna away from the skin.
  - (3) Disconnect the C-type coaxial connector (right angle adapter) from the transponder antenna.
  - (4) Remove the transponder antenna from the airplane.

### 5. Comant Transponder Antenna Installation (Without Cargo Pod)

- A. Install the Transponder Antenna (Refer to Figure 401).
- (1) Make sure that the mounting surface area and the transponder antenna are clean and free of old sealant and contamination. Refer to Chapter 20, Fuel, Weather and High-Temperature Sealing - Maintenance Practices.
  - (2) Put the transponder antenna in position near the skin.
  - (3) Connect the C-type coaxial connector (right angle adapter) to the transponder antenna.
  - (4) Install the screws in the transponder antenna and attach the transponder antenna to the skin.
  - (5) Check the electrical bonding to the airplane of the antenna to Type IV refer to Chapter 20, Electrical Bonding - Maintenance Practices.
  - (6) Engage the applicable circuit breaker given in Table 401.

## 6. Comant Transponder Antenna Post-Maintenance Checks

- A. Do the Comant Transponder Antenna Post-Maintenance Checks.
  - (1) Check the electrical bonding, refer to Chapter 20, Electrical Bonding - Maintenance Practices.
  - (2) Do a Garmin GTX-33/GTX-33ES Transponder System operational check. Refer to Garmin GTX-33/GTX-33ES Transponder System - Adjustment/Test.

## 7. Closeout

- A. Put the Airplane Back to its Initial Condition.
  - (1) Fillet seal the exterior mating surfaces with Type 1 sealant. Refer to Chapter 20, Fuel, Weather and High-Temperature Sealing - Maintenance Practices.

## 8. Comant Antenna Removal (With Cargo Pod or TKS Fairing)

**NOTE:** The airplane can have one or two transponder antennas. The removal and installation procedures for the transponder antennas are typical. The transponder antennas are found on the bottom of the cargo pod at FS 213.74 (208) or FS 261.74 (208B), LBL 11.53 for transponder antenna 1, and FS 213.74 (208) or FS 261.74 (208B), RBL 11.53 for transponder antenna 2.

- A. Remove the Transponder Antenna (Refer to Figure 402 for cargo pod installation).
  - (1) For airplanes with the cargo pod do the steps that follow:
    - (a) Open the cargo pod compartments to get access to the transponder antenna.
    - (b) Disconnect the coaxial connector from the transponder antenna.
    - (c) Remove the screws, washers, and nuts from the transponder antenna.
  - (2) For airplanes with the TKS fairing do the steps that follow:
    - (a) Disconnect the coaxial connector from the transponder antenna.
    - (b) Remove the screws that attach the antenna to the fairing.
  - (3) Carefully pull the transponder antenna away from the cargo pod.
  - (4) Remove the transponder antenna from the airplane.

## 9. Comant Antenna Installation (With Cargo Pod or TKS Fairing)

- A. Install the Transponder Antenna (Refer to Figure 402 for cargo pod installation).
  - (1) Make sure that the mounting surface area and the transponder antenna are clean and free of old sealant and contamination. Refer to Chapter 20, Fuel, Weather and High-Temperature Sealing - Maintenance Practices.
  - (2) For airplanes with the cargo pod do the steps that follow:
    - (a) Put the transponder antenna in its correct position on the cargo pod.
    - (b) Install the screws, washers, and nuts that attach the transponder antenna to the cargo pod.
    - (c) Connect the coaxial connector to the transponder antenna.
  - (3) For airplanes with the TKS fairing do the steps that follow:
    - (a) Put the transponder antenna in its correct position on the fairing.
    - (b) Install the screws that attach the transponder antenna to the fairing.
    - (c) Connect the coaxial connector to the transponder antenna.
  - (4) Check the electrical bonding to the airplane of the installation screws and nuts to Type IV, refer to Chapter 20, Electrical Bonding - Maintenance Practices.
  - (5) Engage the applicable circuit breaker given in Table 401.

## 10. Comant Transponder Antenna Post-Maintenance Checks

- A. Do the Transponder Antenna Post-Maintenance Checks.
  - (1) Do a Garmin GTX-33/GTX-33ES Transponder System operational check. Refer to Garmin GTX-33/GTX-33ES Transponder System - Adjustment/Test.

## 11. Closeout

- A. Put the Airplane Back to its Initial Condition.
  - (1) Fillet seal the exterior mating surfaces with Type 1 sealant. Refer to Chapter 20, Fuel, Weather and High-Temperature

Sealing - Maintenance Practices.

- (2) Close the cargo pod compartments.

Figure 401 : Sheet 1 : Transponder Antenna Without Cargo Pod

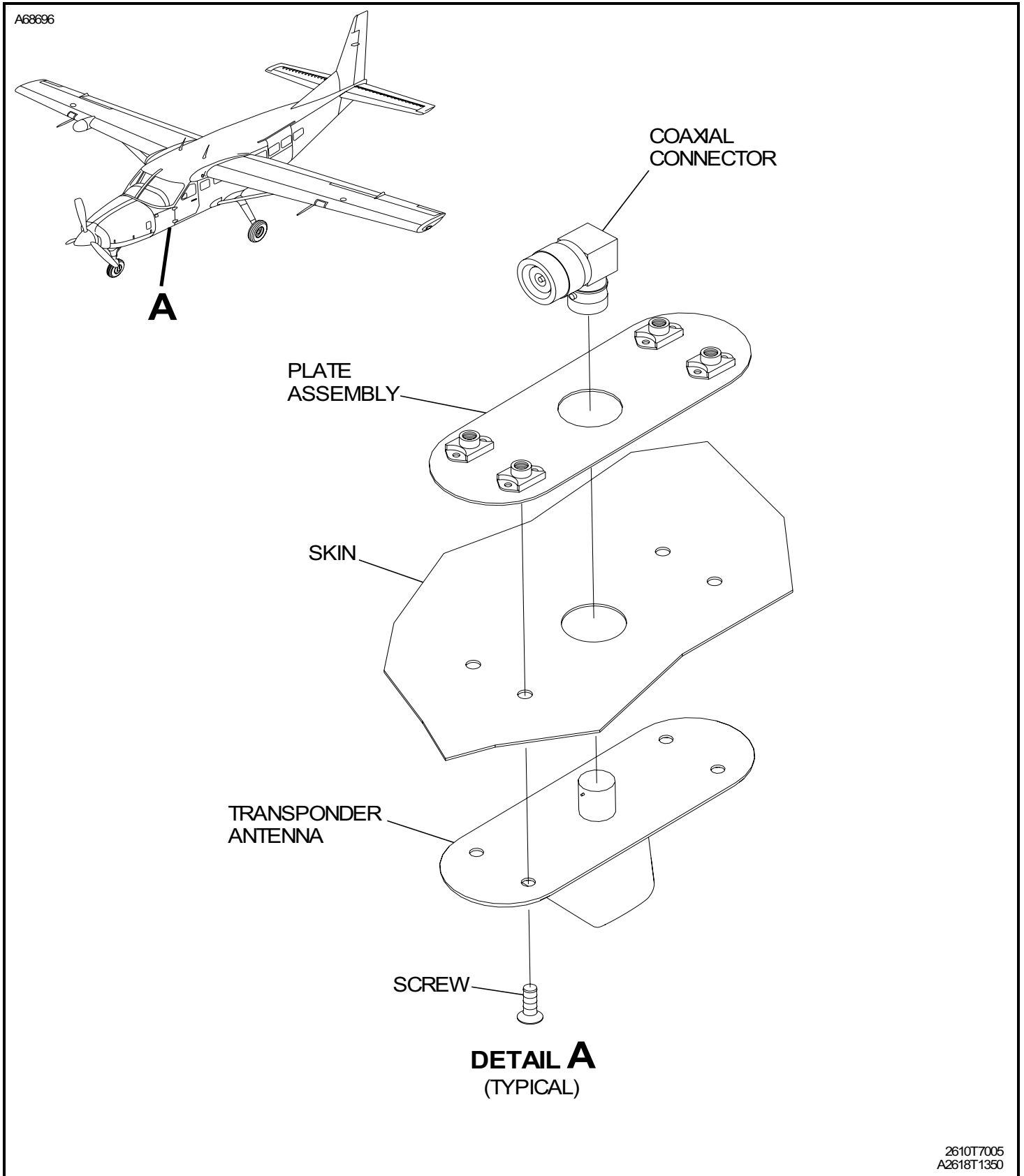

Figure 402 : Sheet 1 : Transponder Antenna With Cargo Pod

